

**Introduction to the Virtual Supply Chain
and Manufacturing Model of the
*Agent.Enterprise NetDemo***

<http://www.agententerprise.net>

presented by
the working group Agent.Enterprise

Hannover, July 24th 2005

Welcome to the *Agent.Enterprise NetDemo*

Our website *www.agententerprise.net* provides you some detailed information about the NetDemo of the *Agent.Enterprise* Virtual Supply Chain and Manufacturing Model.

These information consist of three sets of slides (as PDF files):

- ▶ Introduction and overview (including structure of the scenario and a brief “storybook”), ***this document***
- ▶ Testbed architecture
- ▶ Agent communication protocol



In addition, the interface ontology, which is used to describe information exchanged by the participating multi-agent systems, is available for download.

For further information, please contact *info@agententerprise.net* .

Scenario of *Agent.Enterprise*

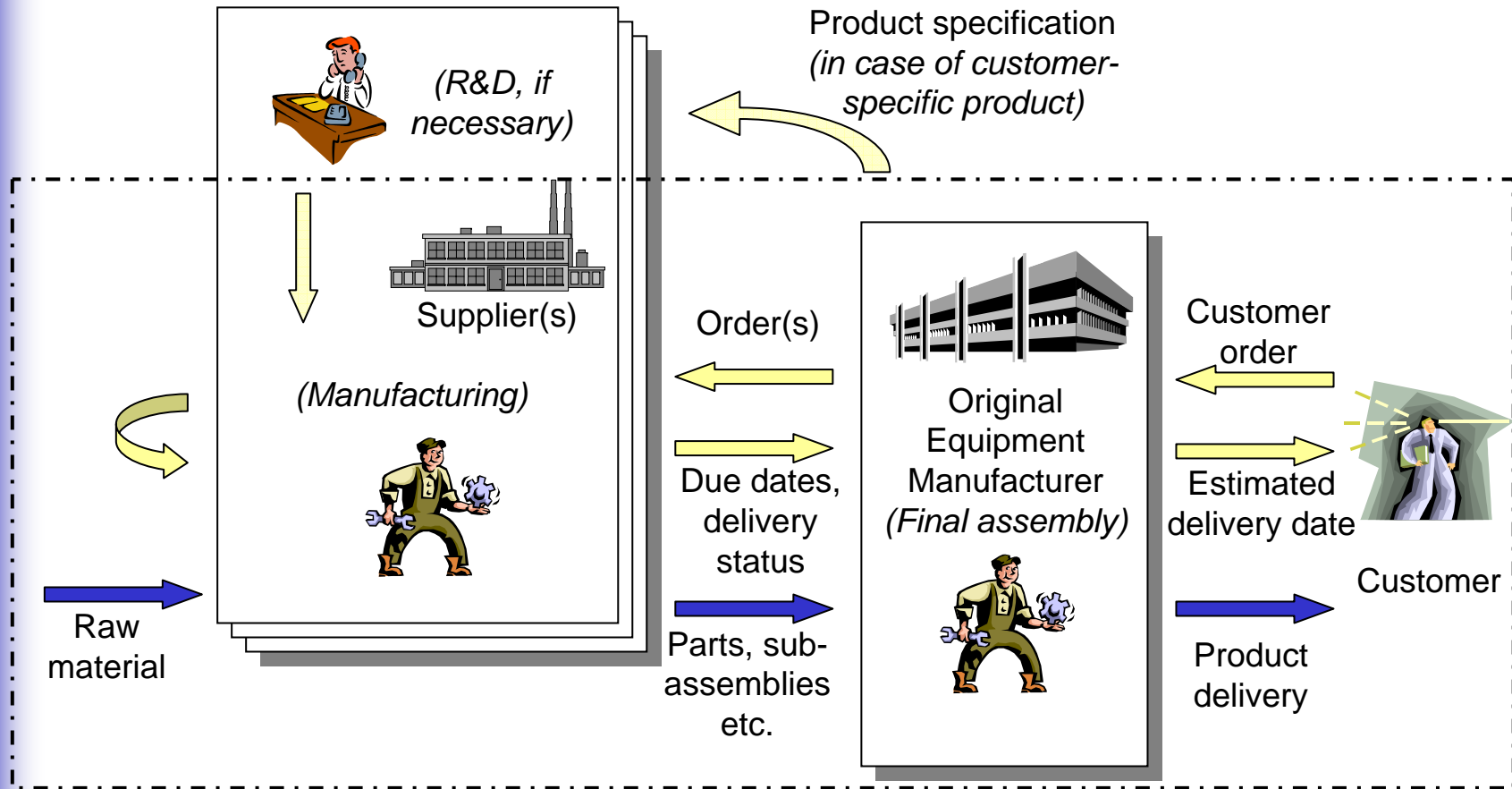
Agent.Enterprise

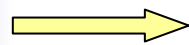

-  Flow of information
-  Flow of material (may involve an external logistics service provider)

Core *Agent.Enterprise* scenario implemented in the *Agent.Enterprise NetDemo*

Involved Research Projects



"P2P-DISPOWEB" *

Prof. König, Dr. Wendt, Frankfurt

Prof. Krallmann, Berlin



"Agent-based Tracking and Tracing (ATT) "

Prof. Bodendorf, Nürnberg

Prof. Görz, Erlangen



"Integrated Agent-based Process Planning and
Production Control (IntaPS)"

Prof. Denkena, Hannover

Prof. Herzog, Bremen



"Karlsruhe Robust Agent Shell (KRASH) / ControMAS"

Prof. Lockemann, Karlsruhe

Prof. Wörn, Karlsruhe

Coordinators: P.-O. Woelk, Hannover; J. Nimis, Karlsruhe

* until 2004

Involved Research Projects

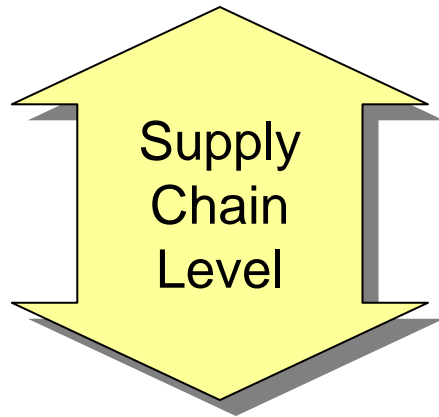

"P2P-DISPOWEB" *

Prof. König, Dr. Wendt, Frankfurt
Prof. Krallmann, Berlin

"Agent-based Tracking and Tracing (ATT)"

Prof. Bodendorf, Nürnberg
Prof. Görz, Erlangen



"Integrated Agent-based Process Planning and Production Control (IntaPS)"

Prof. Denkena, Hannover
Prof. Herzog, Bremen



"Karlsruhe Robust Agent Shell (KRASH) / ControMAS"

Prof. Lockemann, Karlsruhe
Prof. Wörn, Karlsruhe

Coordinators: P.-O. Woelk, Hannover; J. Nimis, Karlsruhe

* until 2004

Involved Research Projects

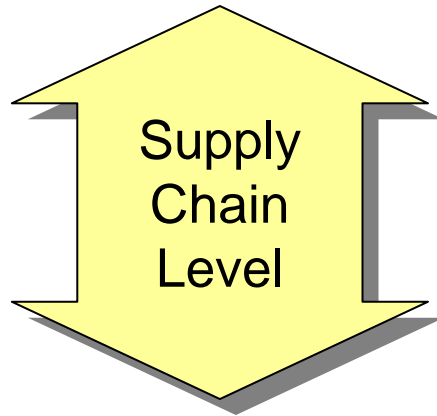

"P2P-DISPOWEB",*
Prof. König, Dr. Wendt, Frankfurt
Prof. Krallmann, Berlin

"Agent-based Tracking and Tracing (ATT)"
Prof. Bodendorf, Nürnberg
Prof. Görz, Erlangen

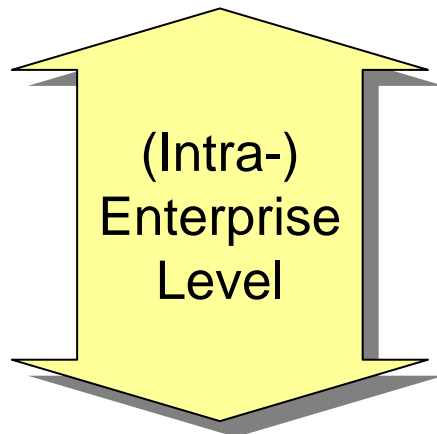

"Integrated Agent-based Process Planning and Production Control (IntaPS)"
Prof. Denkena, Hannover
Prof. Herzog, Bremen

"Karlsruhe Robust Agent Shell (KRASH) / ControMAS"
Prof. Lockemann, Karlsruhe
Prof. Wörn, Karlsruhe

Coordinators: P.-O. Woelk, Hannover; J. Nimis, Karlsruhe

* until 2004

Contributions of the Involved Projects (SC Level)



"P2P-DISPOWEB"
Frankfurt / Berlin



"Tracking & Tracing – Event Mgmt. (ATT)"
Nürnberg / Erlangen

Agent. Enterprise

- ▶ Plan
 - ▶ Execute
 - ▶ Control
- of
- ▶ Source and
 - ▶ Delivery

customer orders, dates,
statistical data, prices etc.

Input information

P2P-DISPOWEB
ATT

Activities:
contract negotiations
tracking of orders
notification

throughput times, order
status, notification events,
economic data etc.

Output information

Contributions of the Involved Projects (Enterprise Level)

IFW



"IntaPS"
Hannover / Bremen



"KRASH / ControMAS"
Karlsruhe / Karlsruhe

Agent. Enterprise

- ▶ Plan
- ▶ Execute
- ▶ Control
- of
- ▶ Production

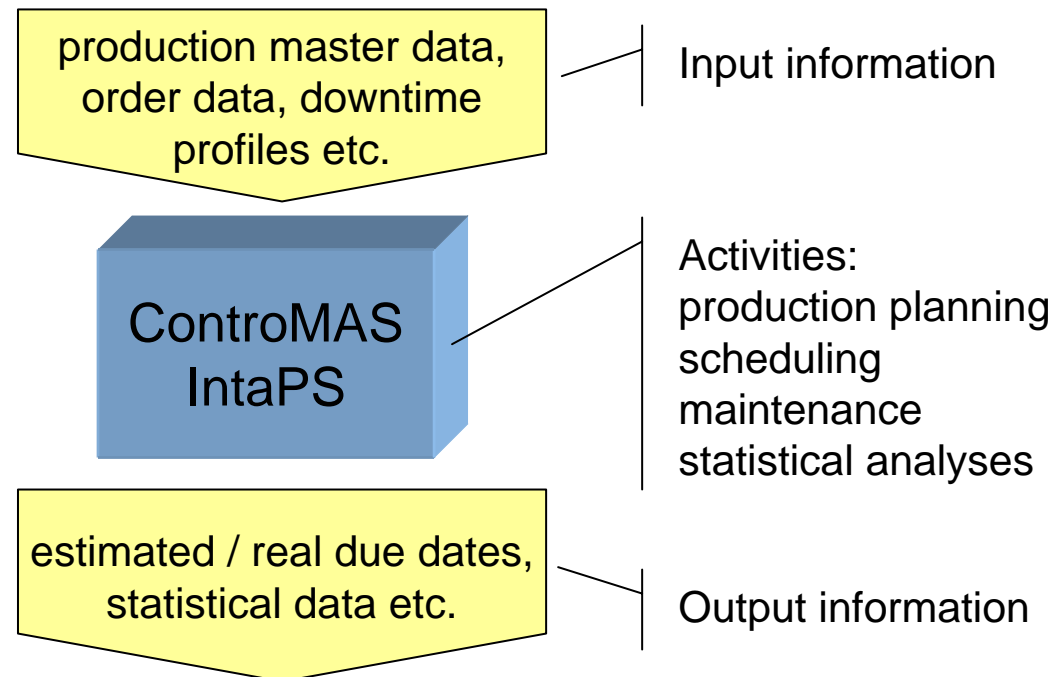

Planned Scenario within Agent.Enterprise

Inter-organisational control loop
(supply-chain level)

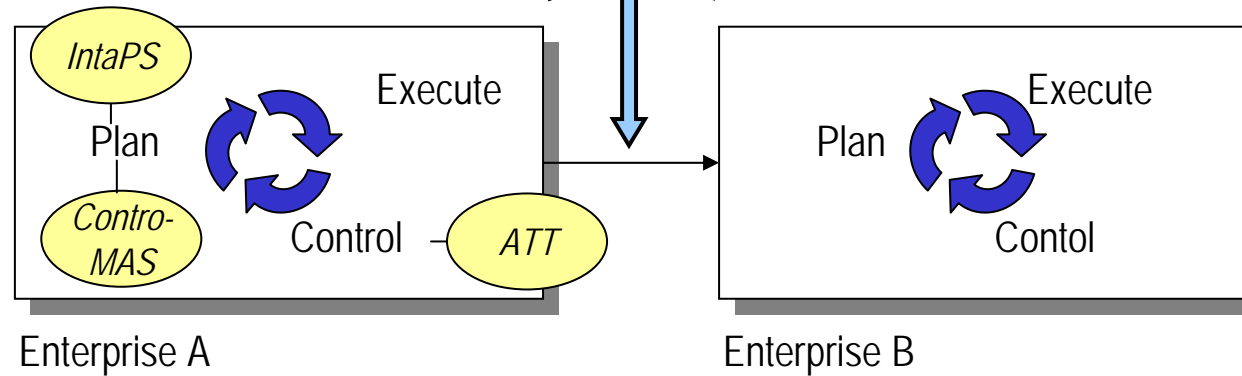
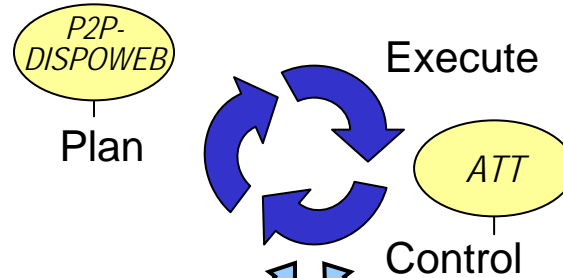

Intra-organisational control loops
(enterprise level)



Interdependencies between control loops

Example Scenario

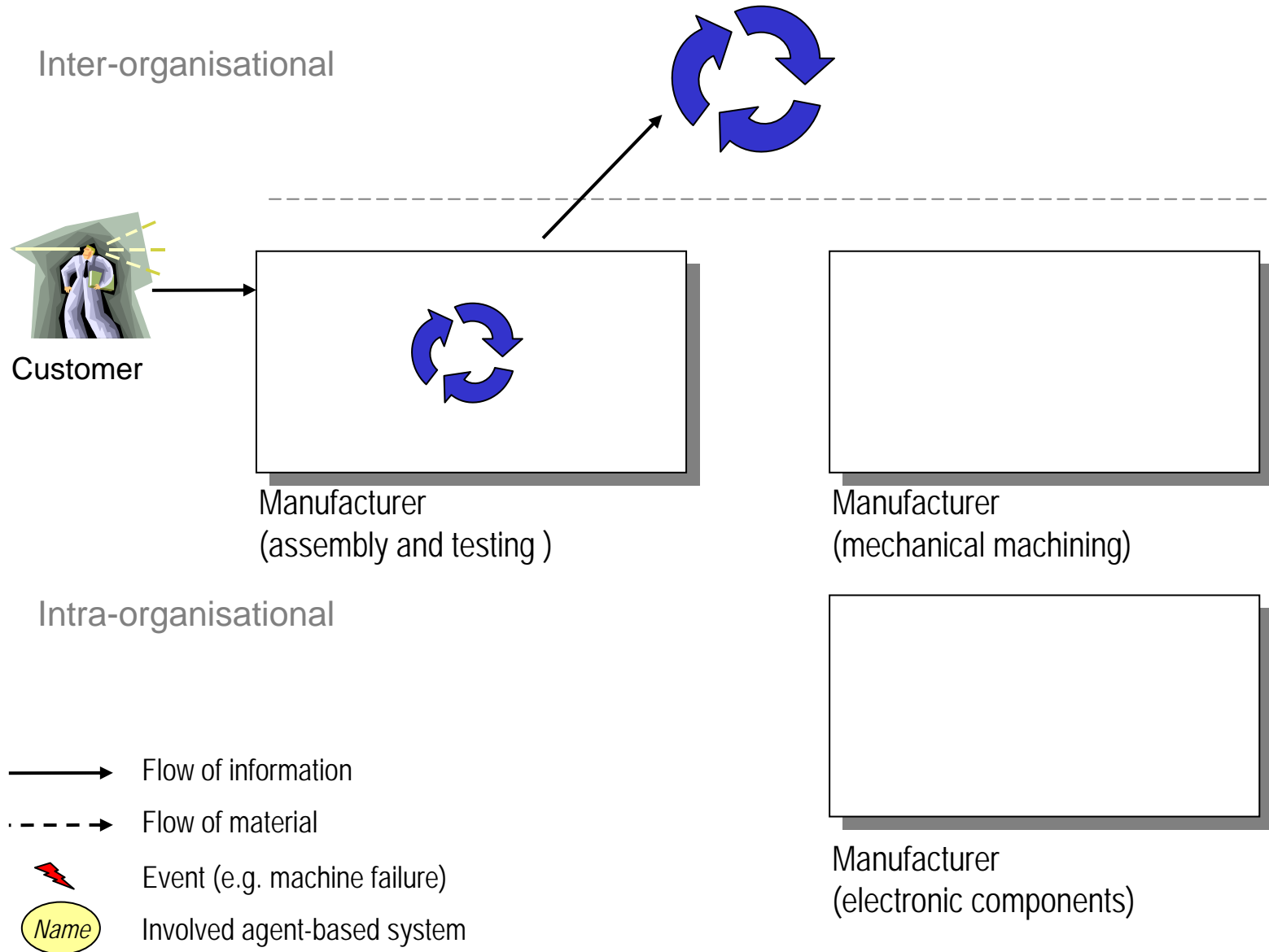

Example Scenario

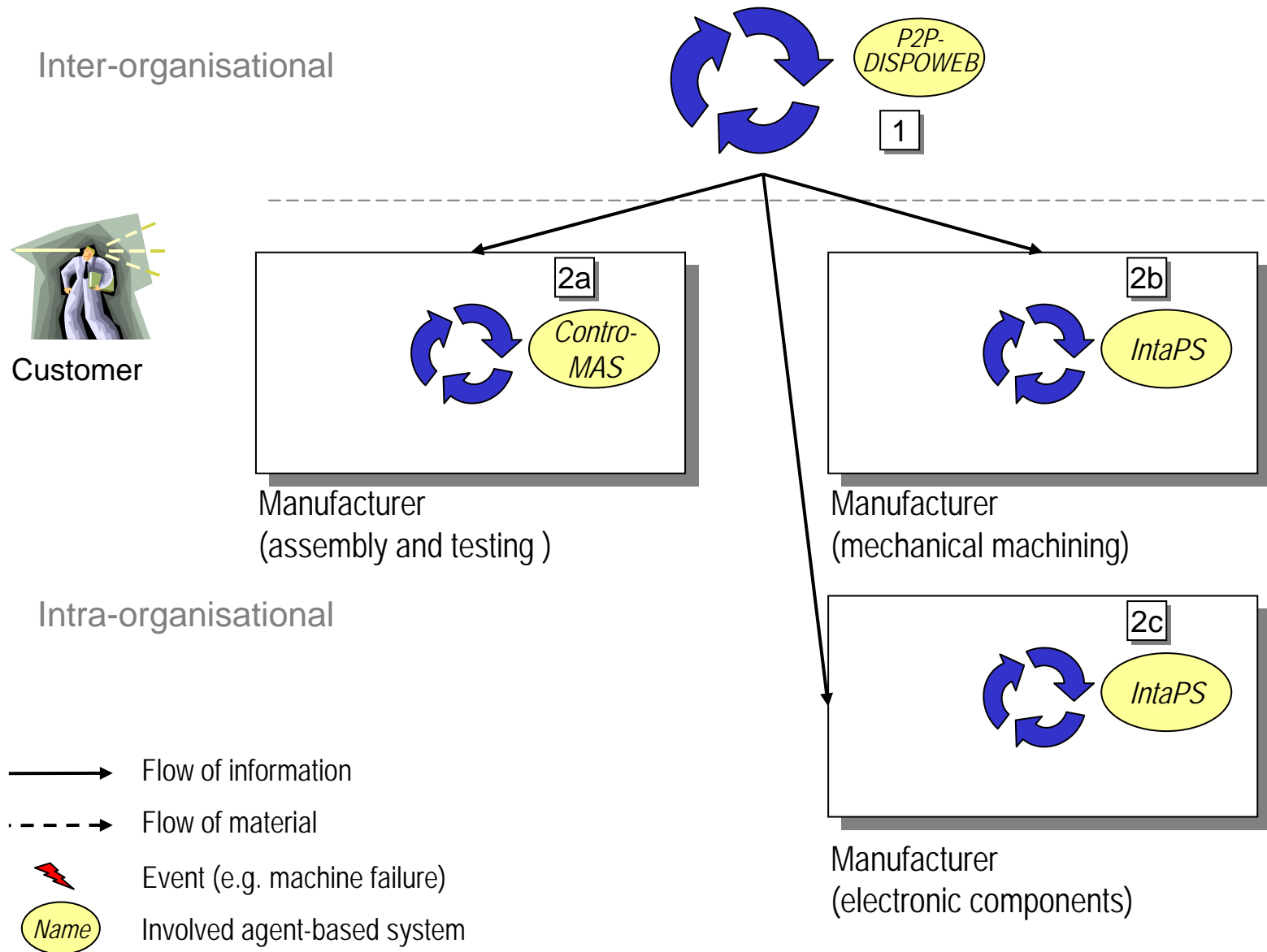

Example Scenario

Inter-organisational

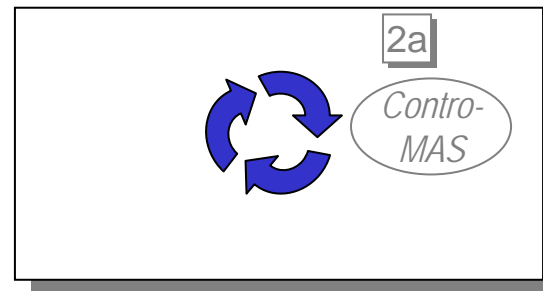
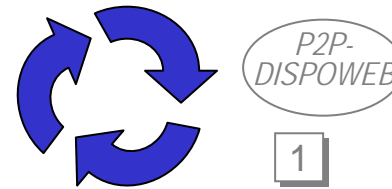

Manufacturer
(assembly and testing)

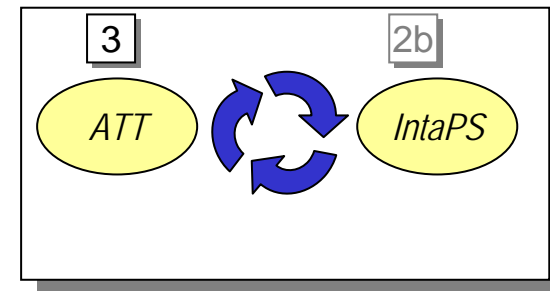

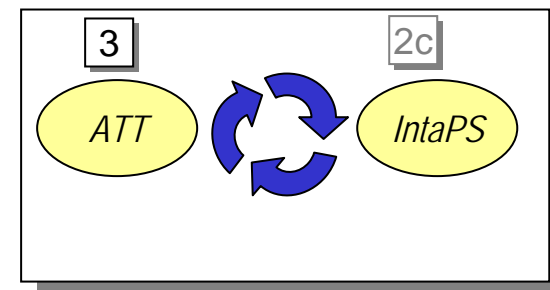

Manufacturer
(mechanical machining)

Intra-organisational

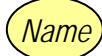

Manufacturer
(electronic components)

-  Flow of information
-  Flow of material
-  Event (e.g. machine failure)
-  Involved agent-based system

Example Scenario

Inter-organisational

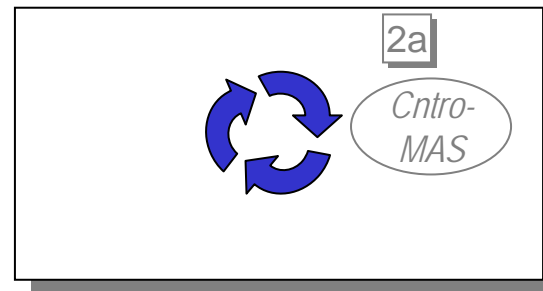
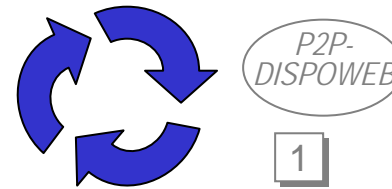

Manufacturer
(assembly and testing)

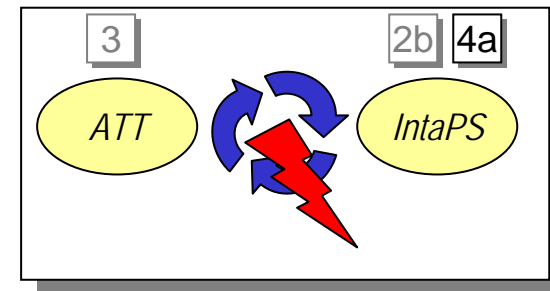

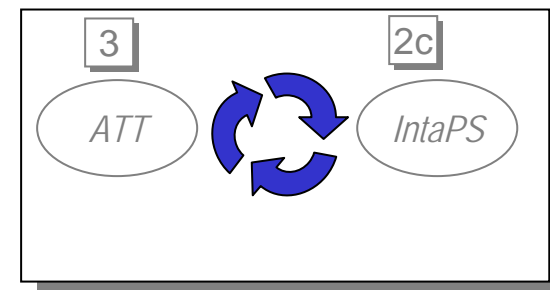

Manufacturer
(mechanical machining)

Intra-organisational

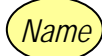

Manufacturer
(electronic components)

-  Flow of information
-  Flow of material
-  Event (e.g. machine failure)
-  Involved agent-based system

Example Scenario

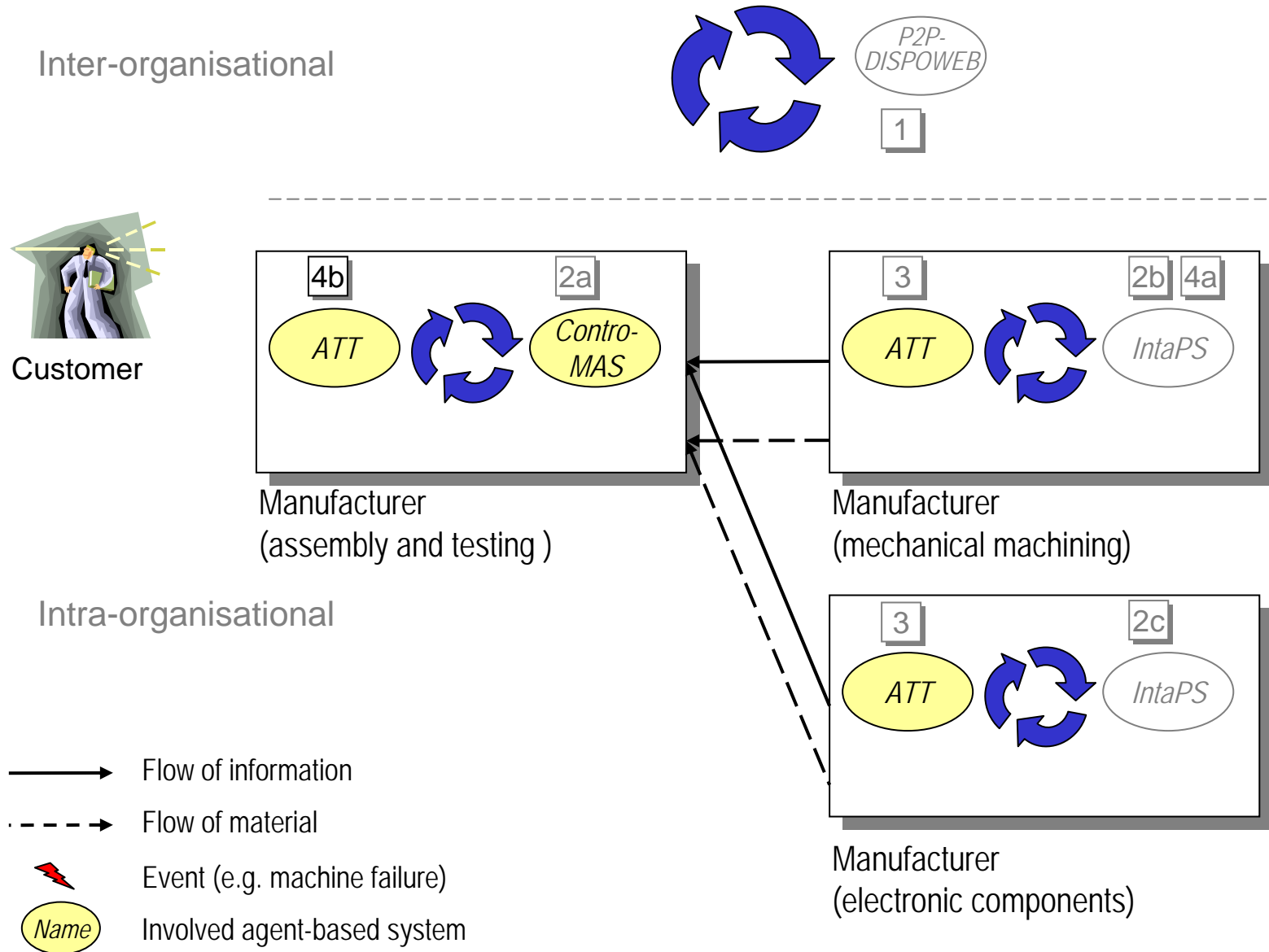

Example Scenario

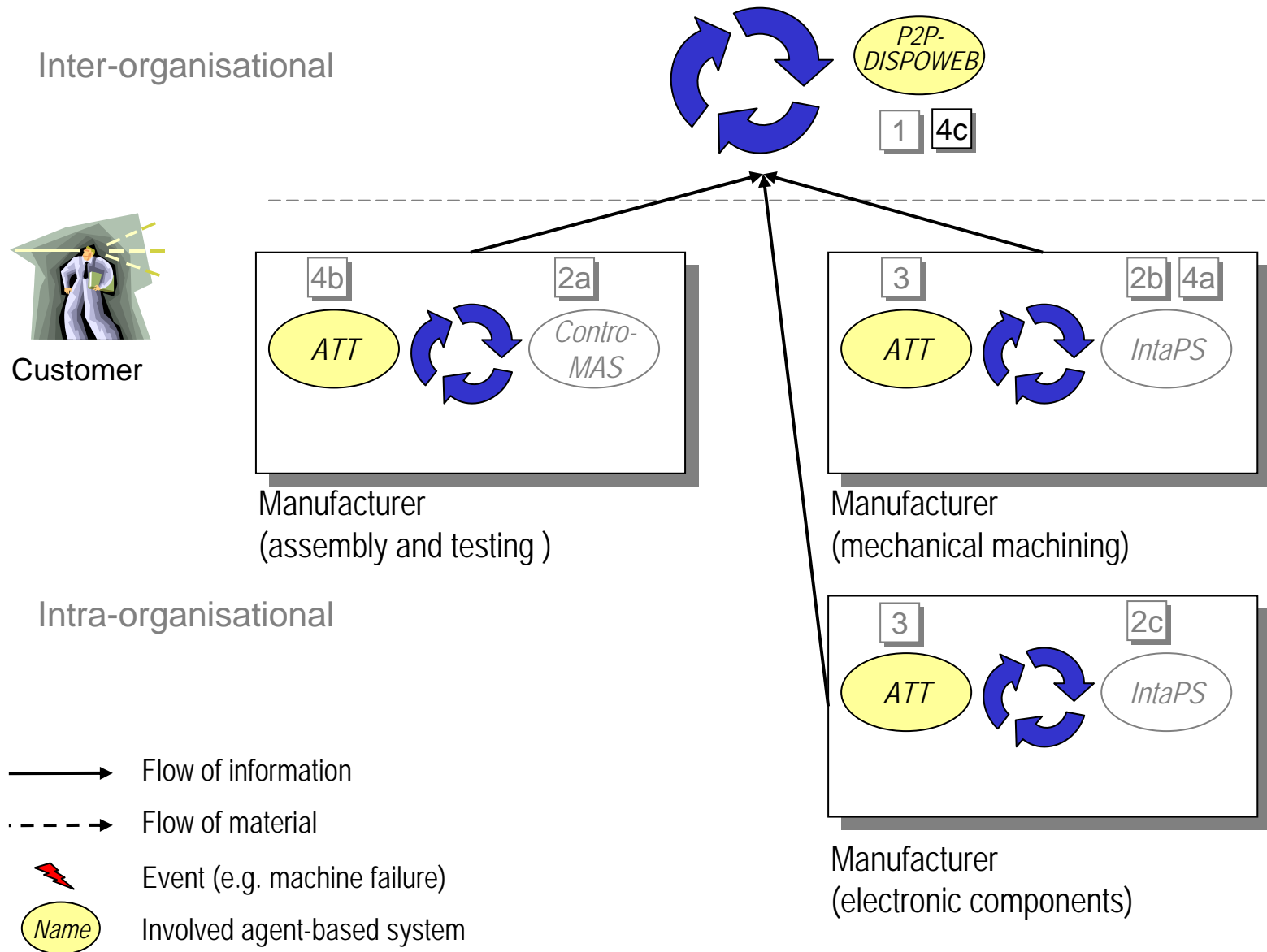

Example Scenario

Inter-organisational

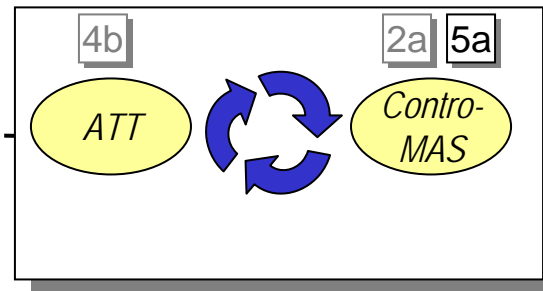
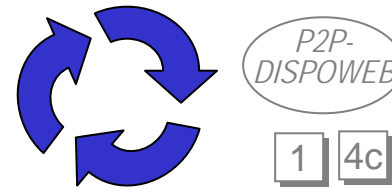

Manufacturer
(assembly and testing)

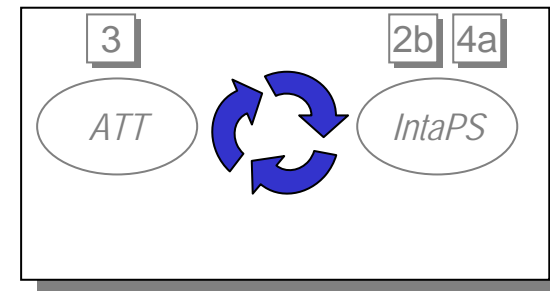

Manufacturer
(mechanical machining)

Intra-organisational

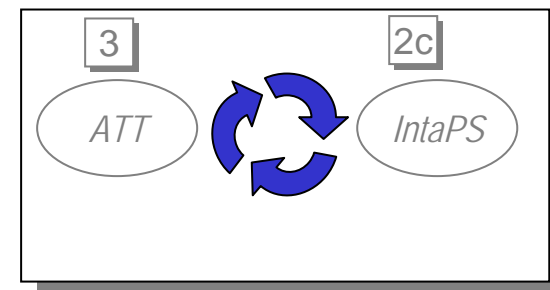

Manufacturer
(electronic components)

- Flow of information
- Flow of material
- Event (e.g. machine failure)
- Involved agent-based system

Example Scenario

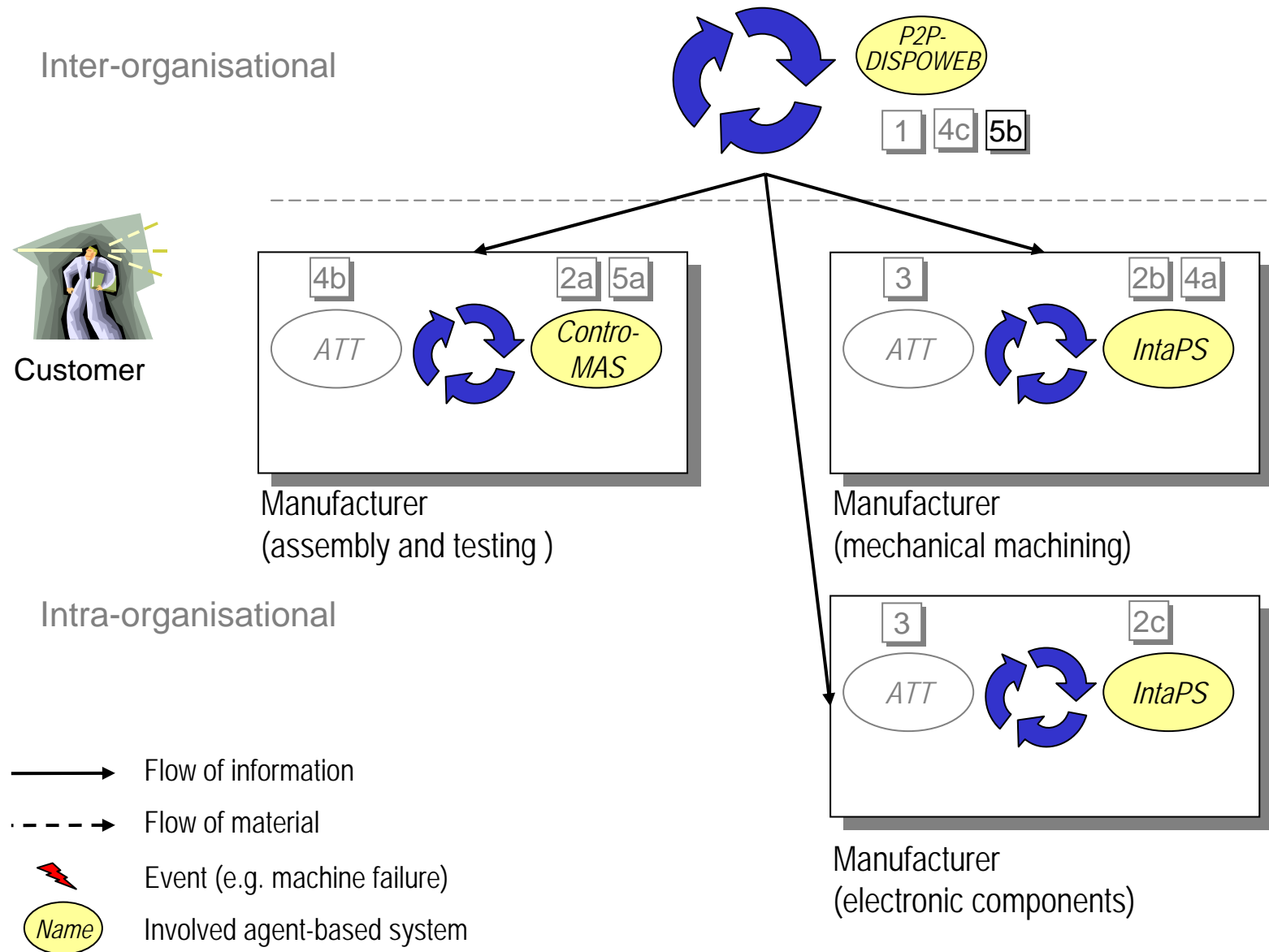

Current Participants of *Agent.Enterprise*

Agent.Enterprise

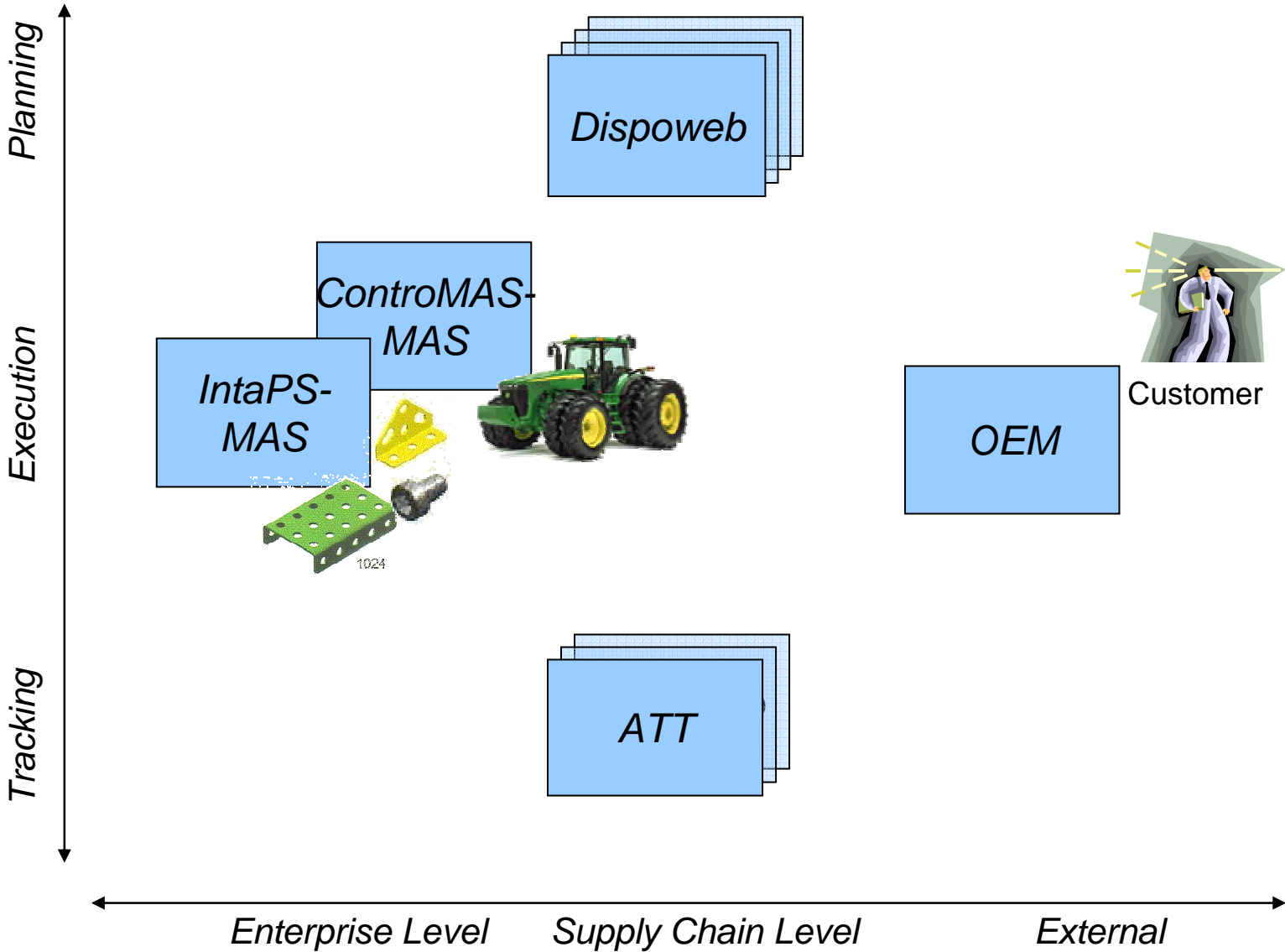

Agent.Enterprise NetDemo Example Product

- ▶ Our example product is a tractor model.
- ▶ Although it looks like a “toy”, it has all the characteristic properties of an industrial, “real” product: Parts, (sub-) assemblies, bills-of-material, suppliers, “make-or-buy” decisions etc.



*“Real” tractor
(John-Deere)*



Tractor model as example product





Agent.Enterprise NetDemo Product Database

Agent.Enterprise

- ▶ You can browse through the product structure and the *Agent.Enterprise* Product Database at <http://dispoweb.ifw.uni-hannover.de>

Agent.Enterprise Product Database

Products

Product	Picture	Bill of Materials	Operations
testprodukt4711	Dummy 4711	show bill of materials	show suppliers
testprodukt4712	Dummy 4712	show bill of materials	show suppliers
tractor 1		show bill of materials	show suppliers
tractor 2		show bill of materials	show suppliers
tractor 3		show bill of materials	show suppliers
trailer		show bill of materials	show suppliers

Fertig

The *Agent.Enterprise NetDemo* Story

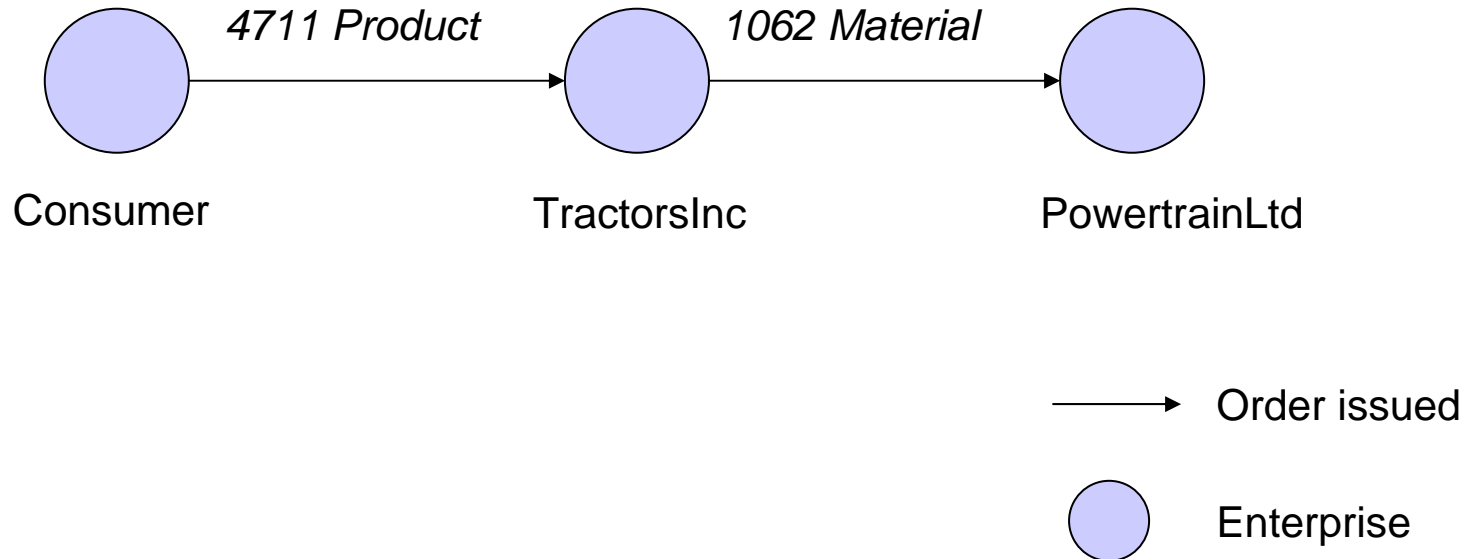

(For simplicity, this story board uses a very simple product.)

- ▶ The *Agent.Enterprise NetDemo* story:
Issuing, Planning and Controlling Customer-Orders

Supply Chain Triggered by Consumer

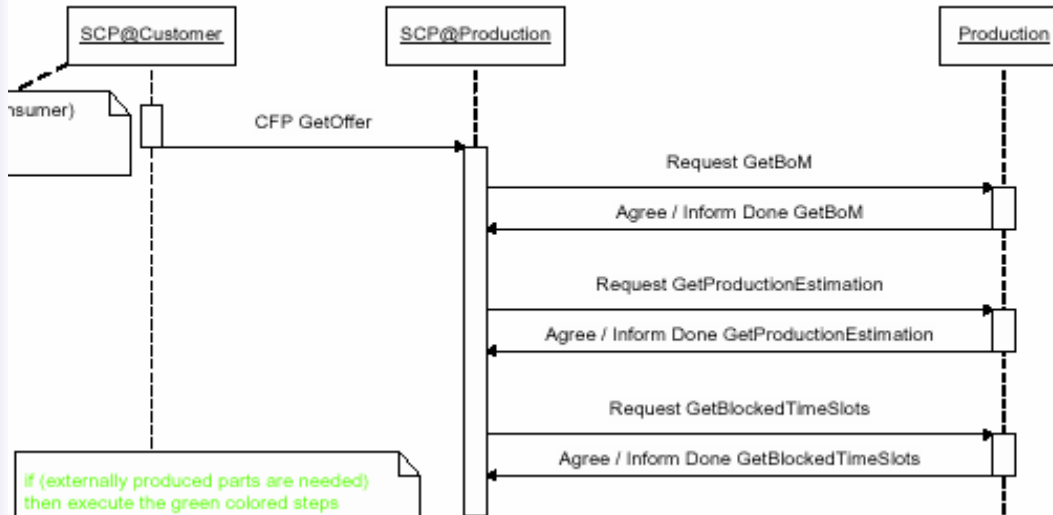

1. The consumer orders a product (e.g. 4711) from manufacturer *TractorsInc* by sending a CfP
2. Dispoweb agent of *TractorsInc* negotiates with production planning (*ControMas*) and sends blocked time-slots for

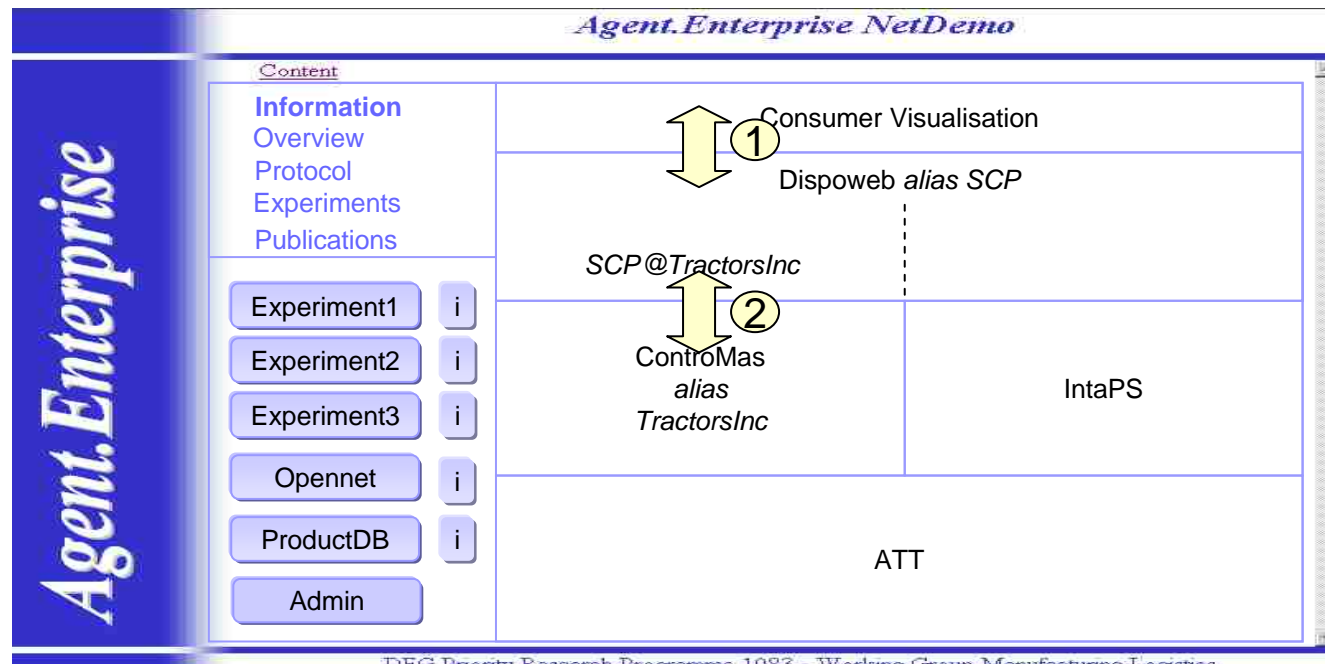

DFG Priority Research Programme 1083 - Working Group Manufacturing Logistics

Suborder for Material Initiated

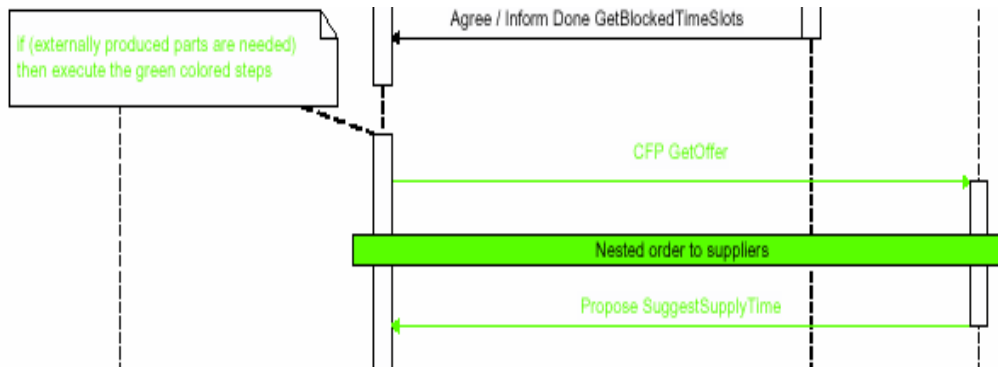

Manufacturer *TractorsInc* identifies need to procure parts from supplier *PowertrainLtd* → Call-for-Proposal (CfP) for MaterialID (e.g. 1062) → nested protocol within first CfP conducted by *DispoWeb* agents

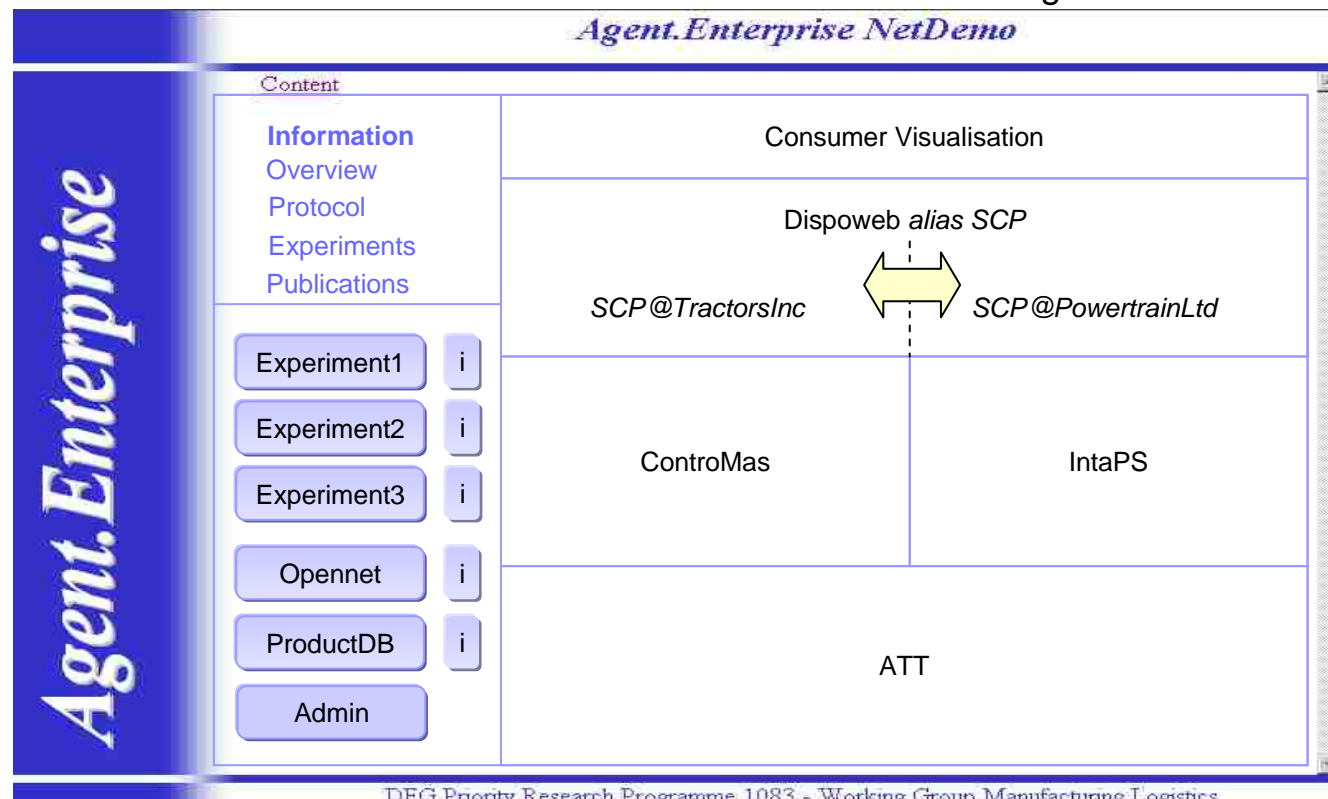

Production Planning Initiated at Supplier PowertrainLtd

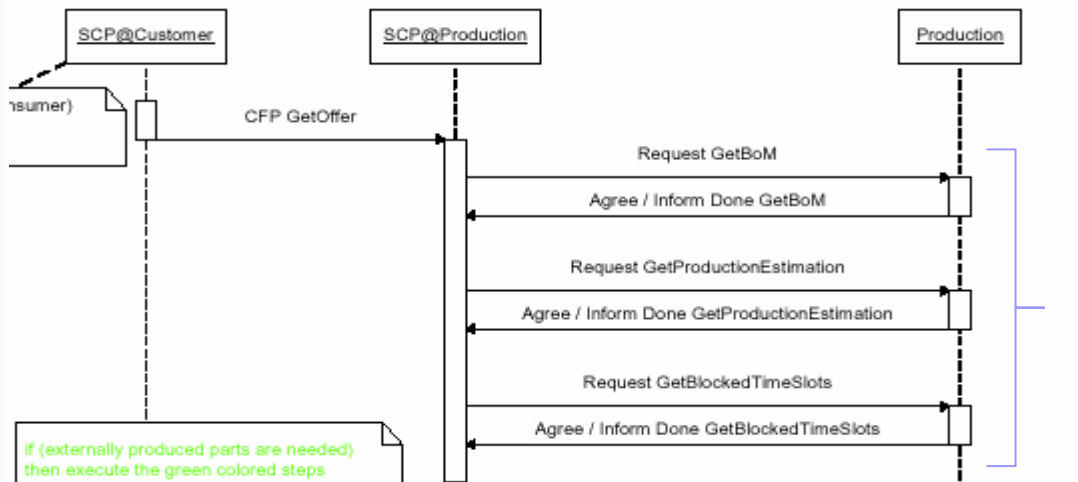

Negotiation between *DispoWeb* and *IntaPS* for internal production planning of product (1062) → Blocked time-slots as result

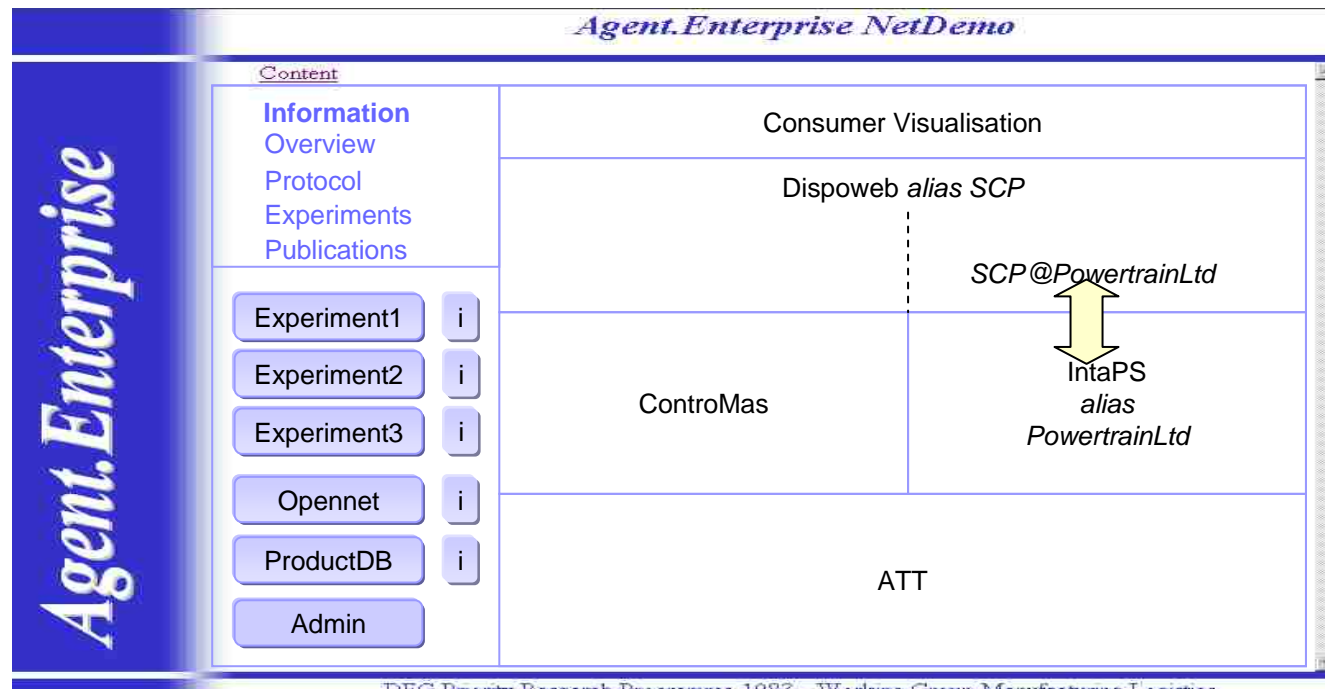

Reservation of Time-Slots at Supplier, Supply Proposal

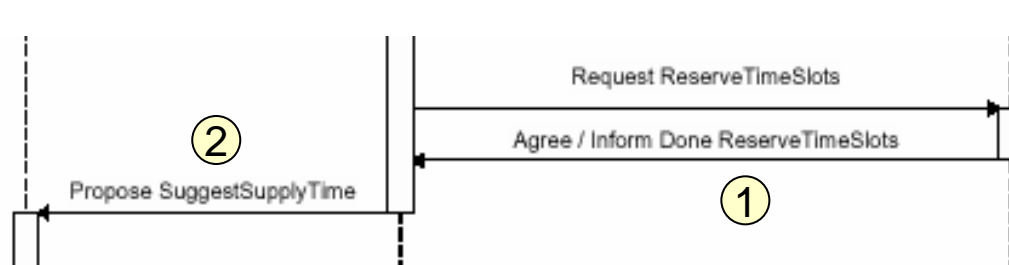

1. *DispoWeb* agent of *PowertrainLtd* reserves time-slots in production
2. *DispoWeb* agent of *PowertrainLtd* sends proposal for delivery of supplier material (1062) to *TractorsInc*

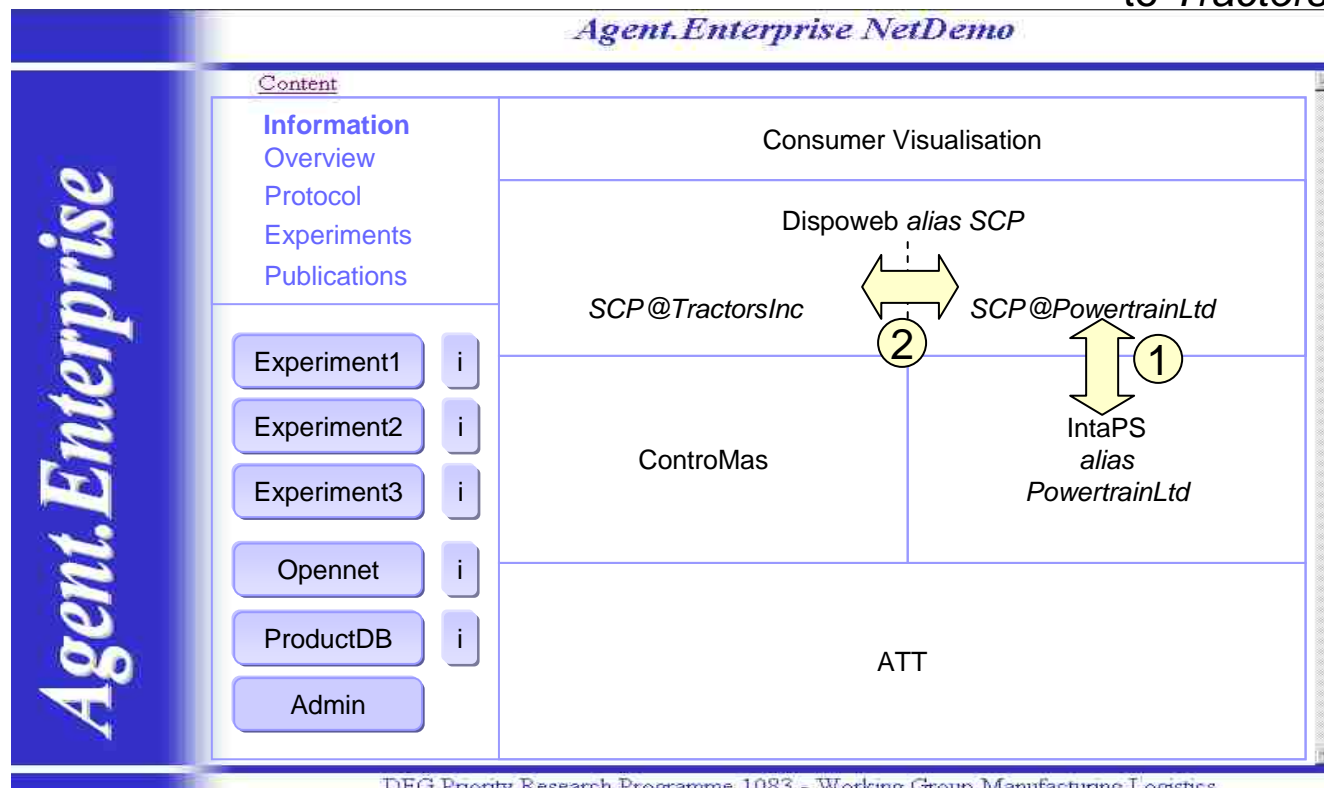

Production Time-Slot of Main Product is Reserved

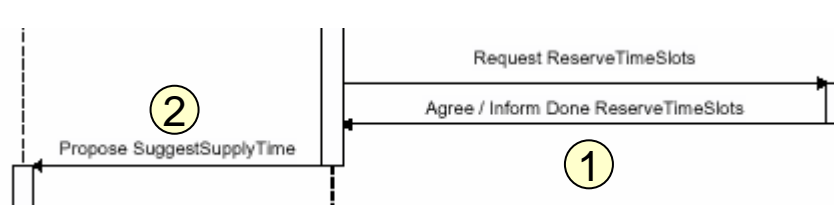

1. *DispoWeb* agent of *TractorsInc* reserves time-slots in production
2. *DispoWeb* agent of *TractorsInc* sends proposal for delivery of product (4711) to *Consumer*

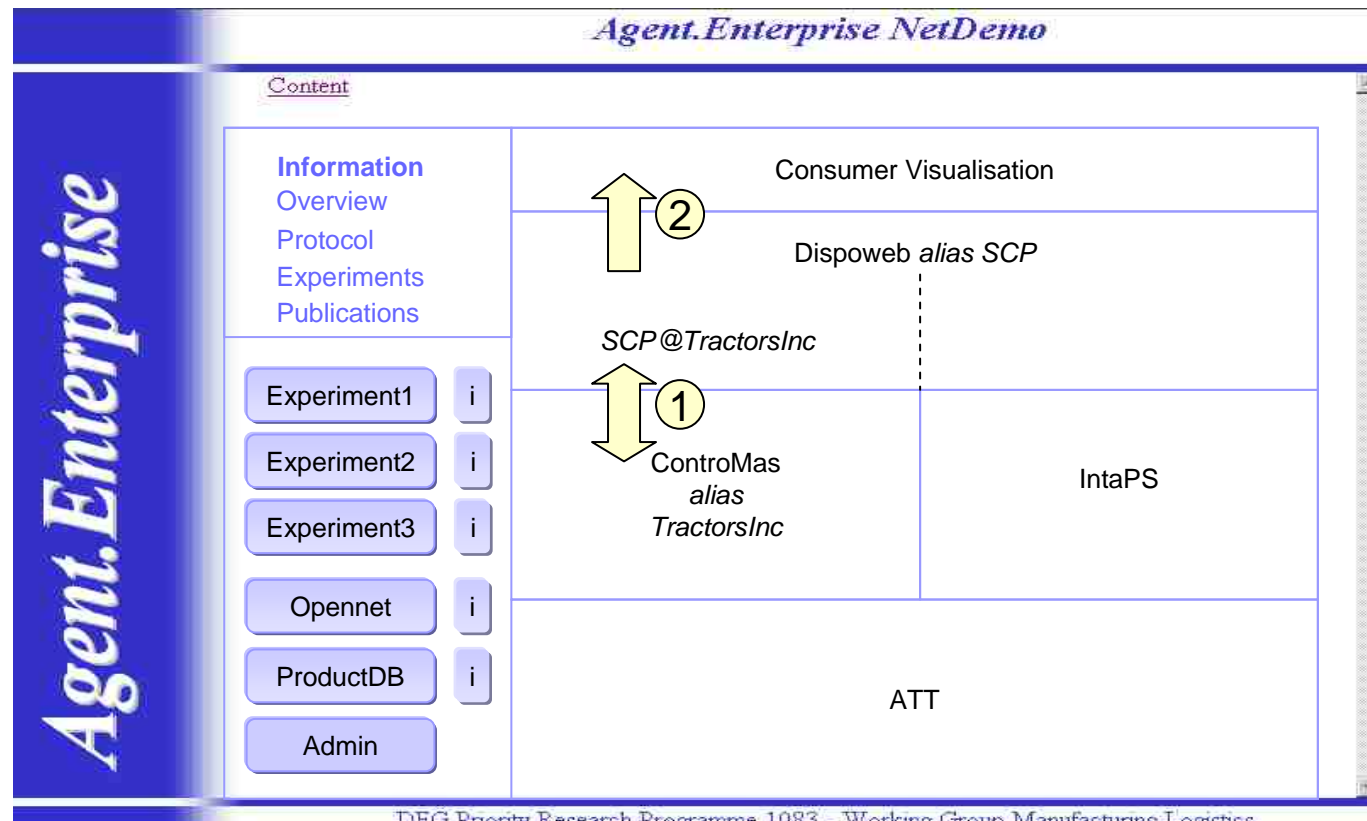

DFG Priority Research Programme 1083 - Working Group Manufacturing Logistics

Consumer Accepts Delivery Plan

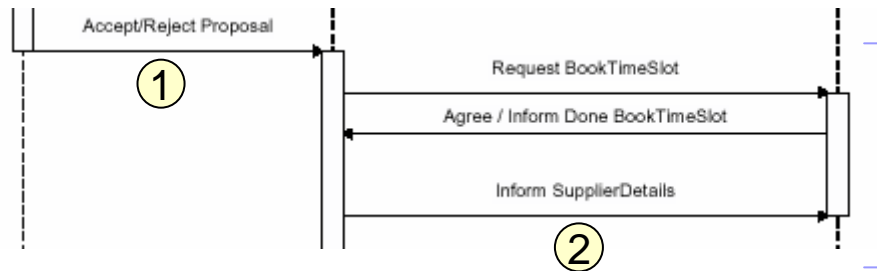

1. Consumer accepts delivery time proposal
2. Time-slots for production of 4711 are finally booked at *TractorsInc* by *DispoWeb* agent and *ControMas*

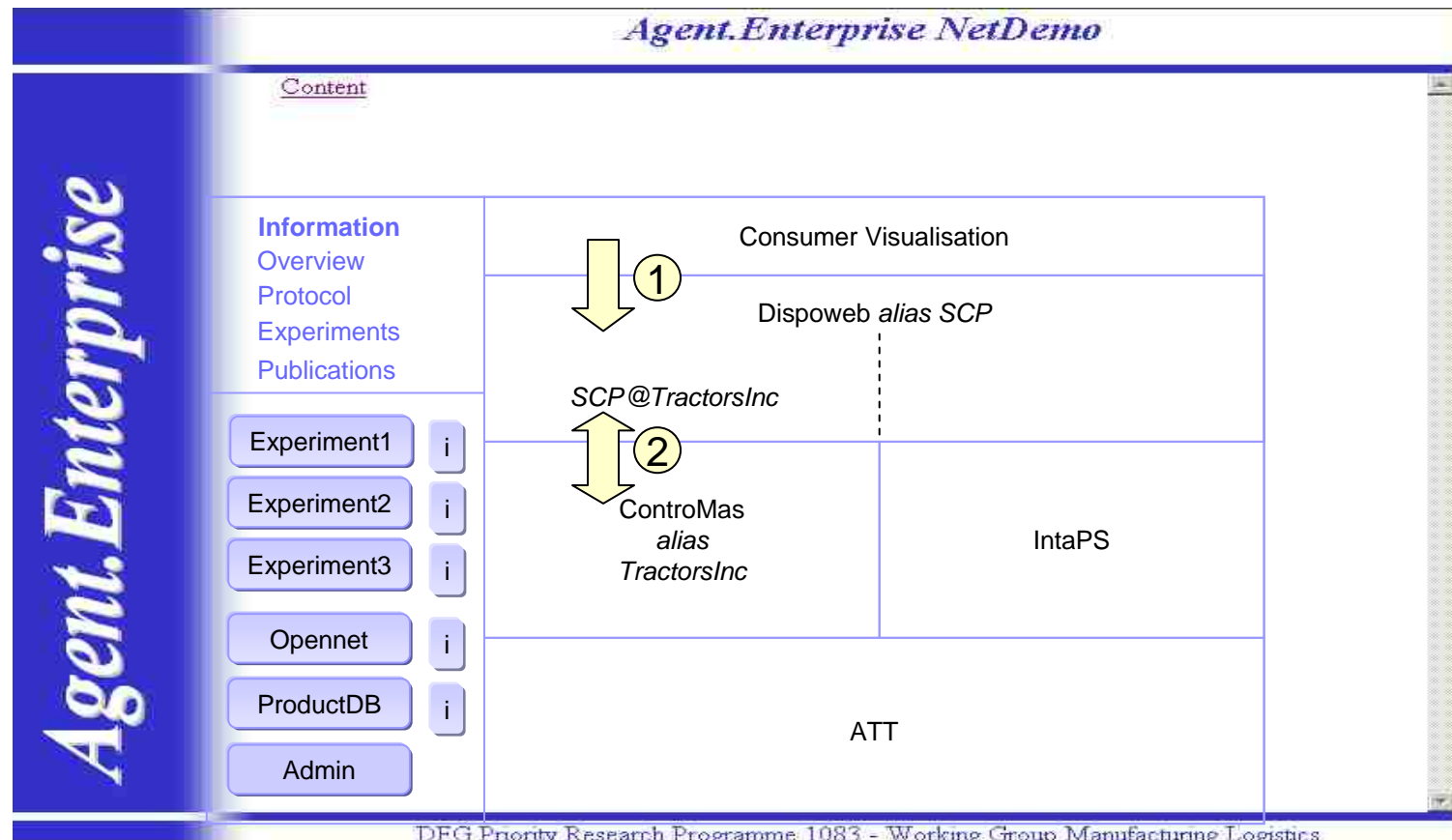

Delivery Schedule for Material is Accepted



DispoWeb agent of *TractorsInc* accepts proposal for delivery of material (1062) from *PowertrainLtd* → closes the nested CFP

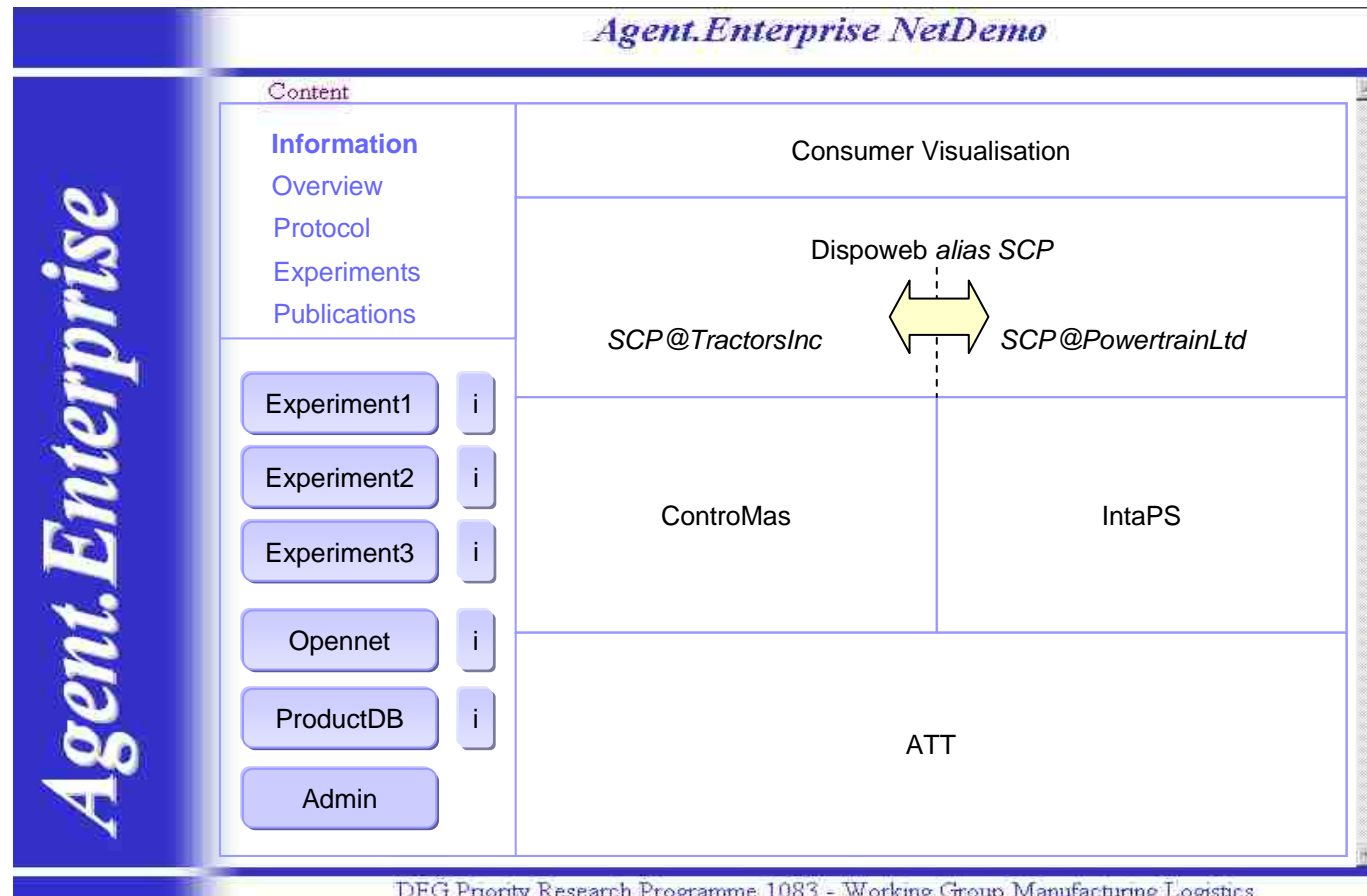

Agent Enterprise

Production at Supplier is Finally Scheduled

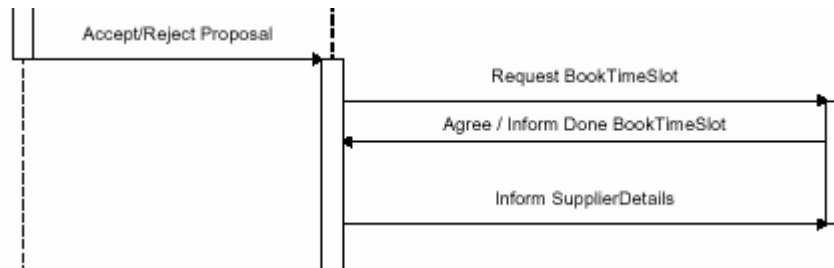

Accepted proposal for material (1062) results in booking of time-slots for production at *PowertrainLtd*

- Planning of orders is finished
- Order fulfillment begins

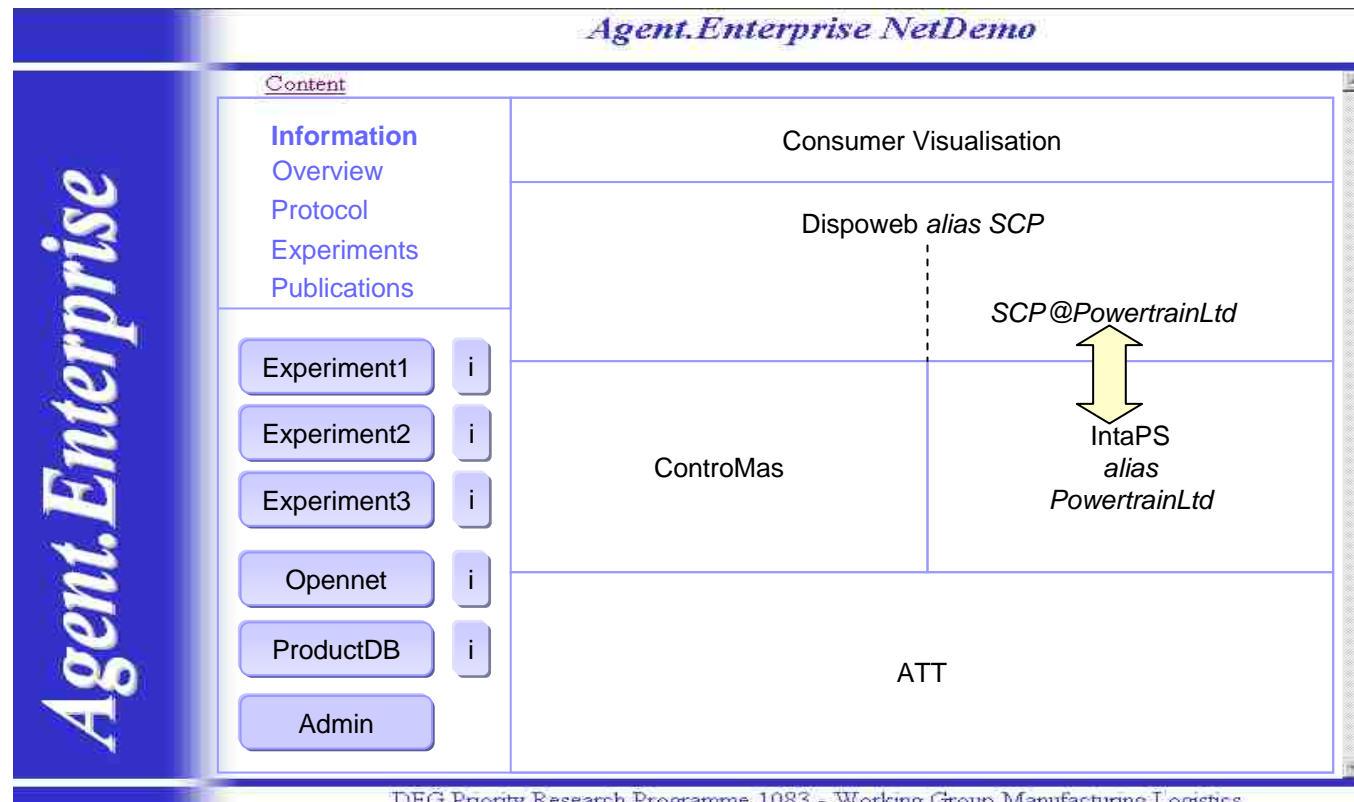

Fulfillment Monitoring Initiated for Whole Supply Chain

Agent.Enterprise

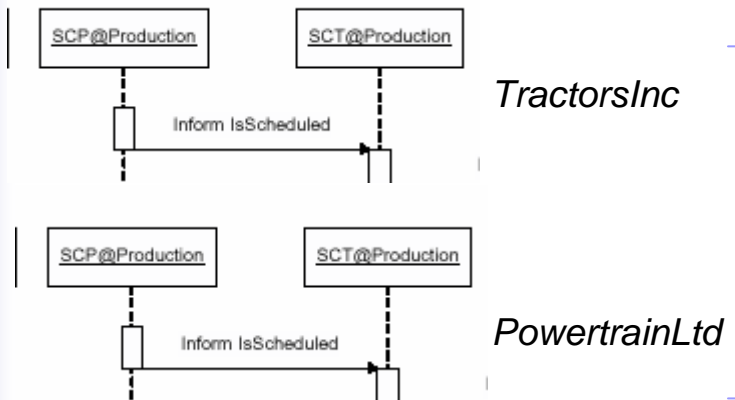

Both *DispoWeb* agents of *TractorsInc* and *PowertrainLtd* inform their enterprise's tracking agent system (ATT) → overview visualization is initialized

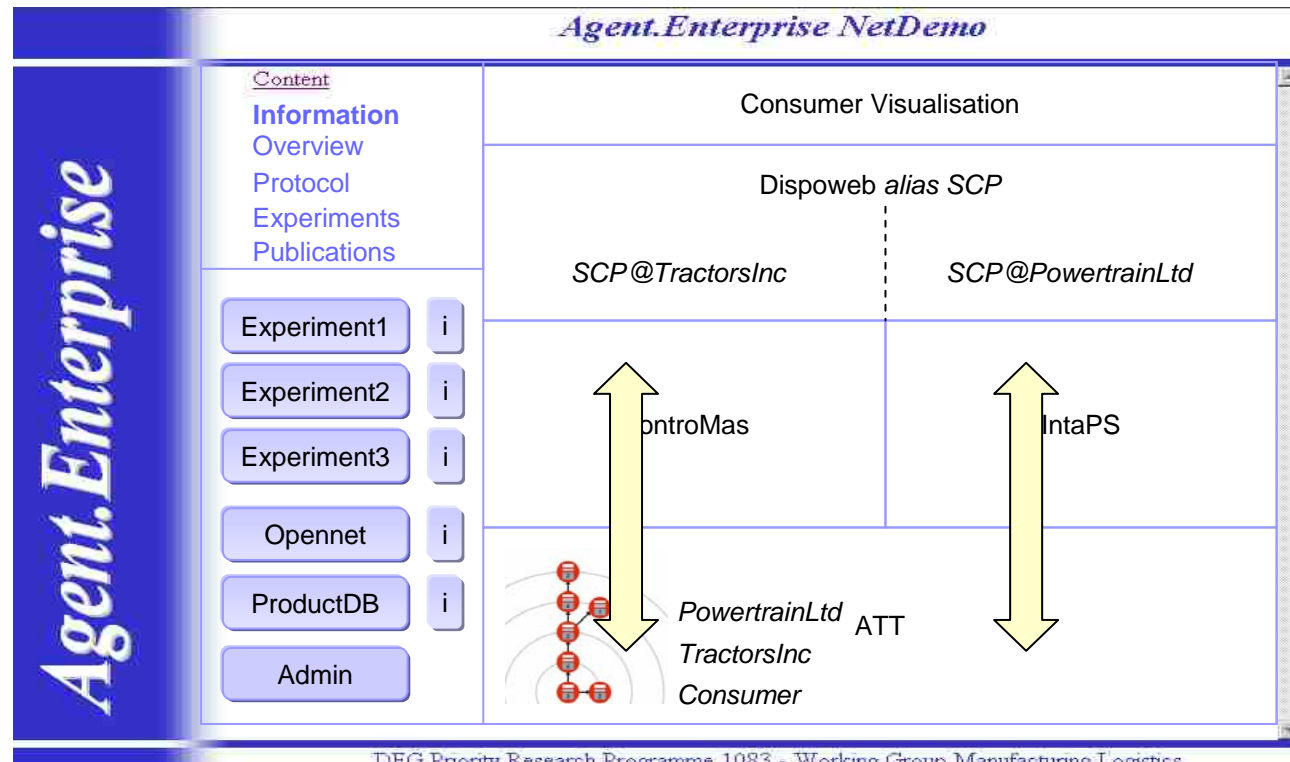

DFG Priority Research Programme 1083 - Working Group Manufacturing Logistics

Proactive Monitoring in Supply Chain

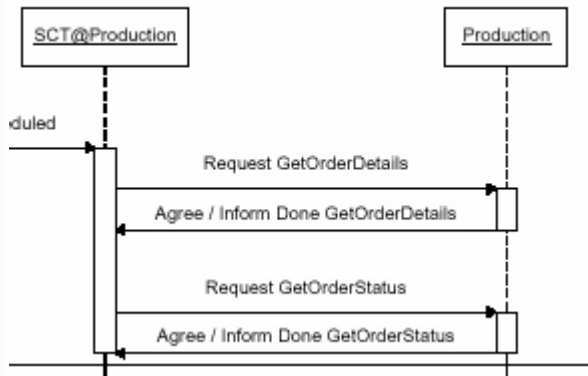

ATT agent systems of *TractorsInc* and *PowertrainLtd* request information updates from production planning MAS.

ATT agent systems also communicate among each other illustrated in the centralized visualization (not part of the *Agent.Enterprise* protocol)

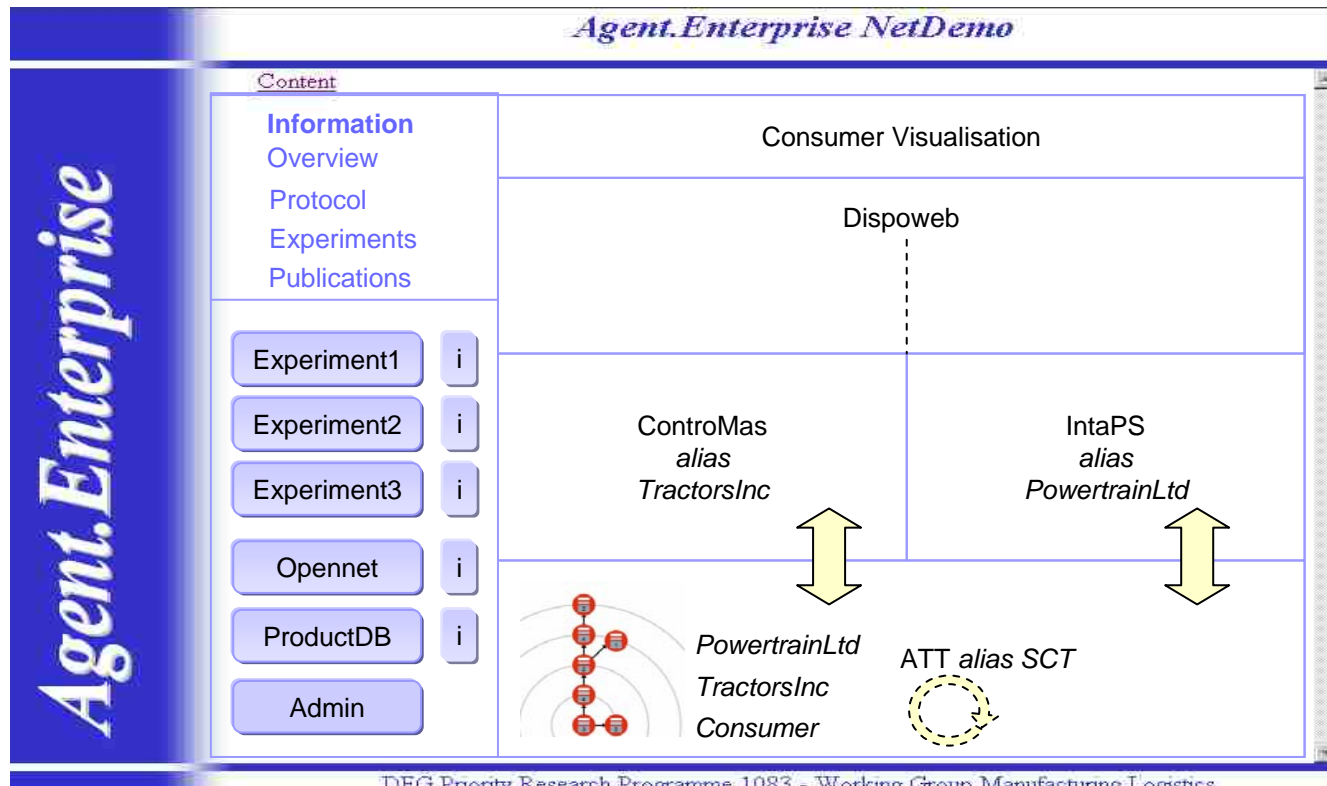

DFG Priority Research Programme 1083 - Working Group Manufacturing Logistics

Fulfillment Problem is Identified, Rescheduling Initialized

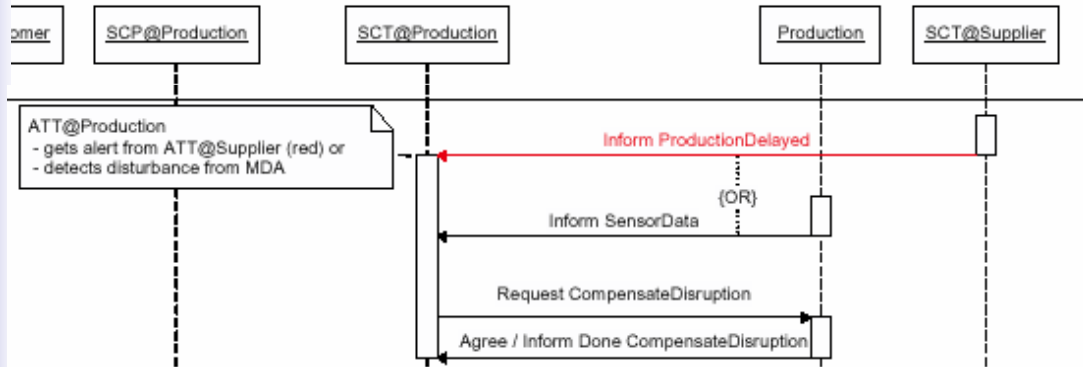

- A disruptive event is identified:
1. Identified by *PowertrainLtd's* ATT system and an alert forwarded to *TractorsInc*
 2. Internal problem at *TractorsInc* is identified by *TractorsInc's* ATT agent system Request for replanning is sent to *TractorsInc's* production planning (*ControMas*)

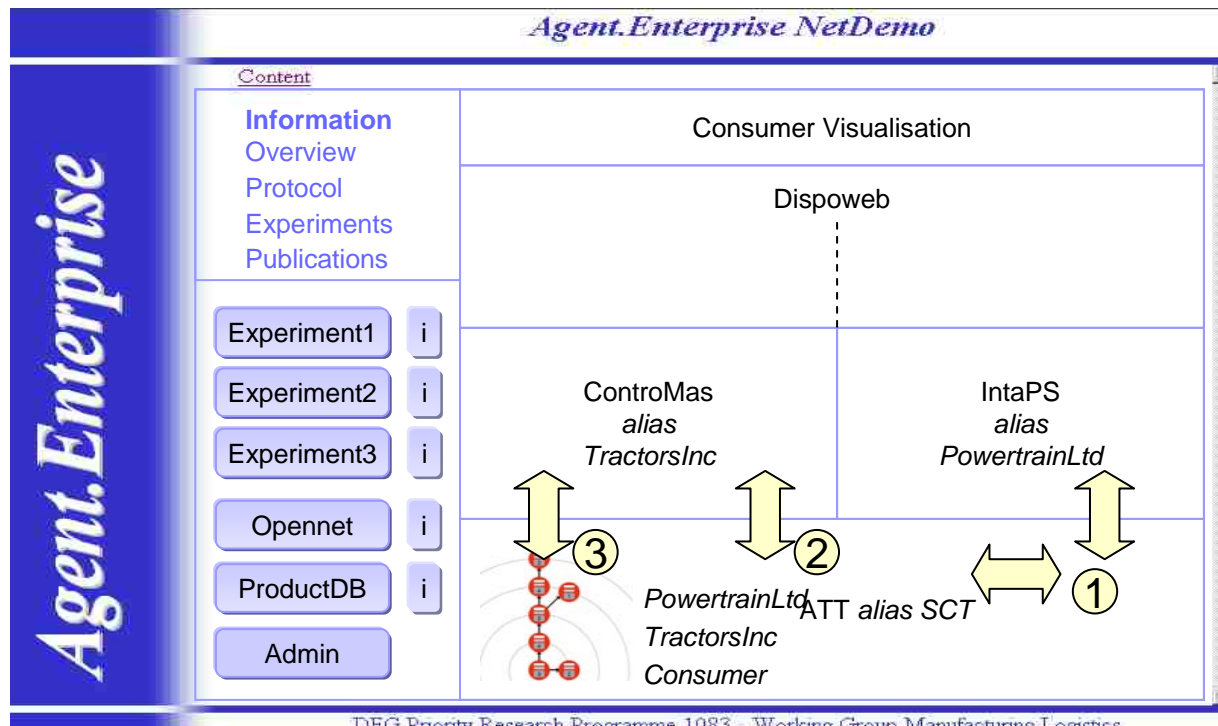

DFG Priority Research Programme 1083 - Working Group Manufacturing Logistics